

AUBO-iS7

iS Series Collaborative Robot

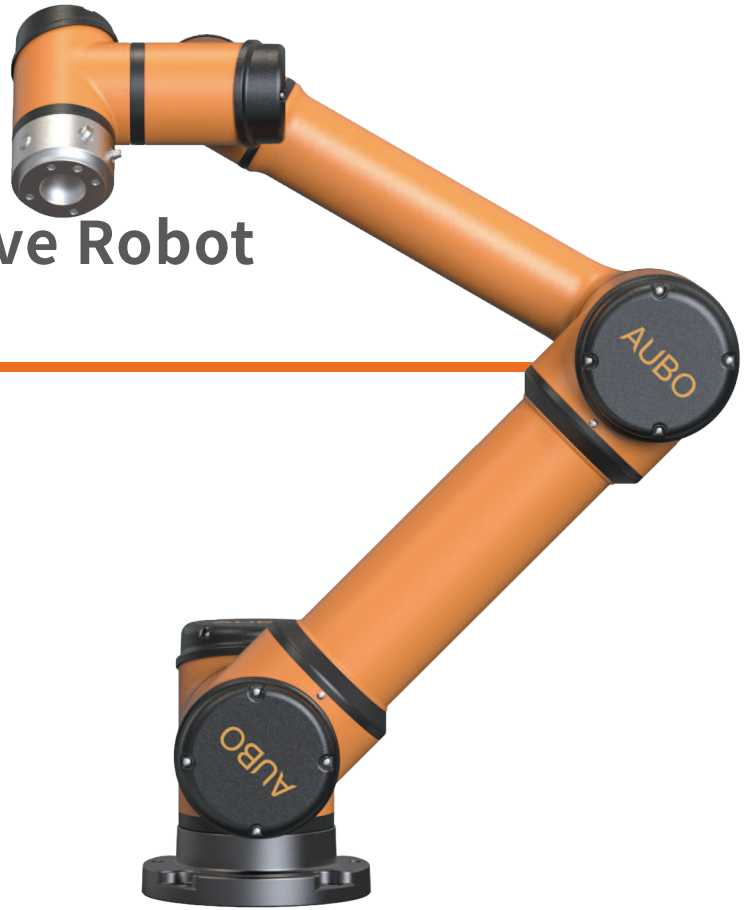

7KG
PAYLOAD



21.5KG
WEIGHT



±0.02mm
REPEATABILITY



886.5mm
WORKING RADIUS

- ✓ The AUBO-iS7 high-performance collaborative robot boasts a fast-operating robotic arm, capable of meeting the operational needs in complex and sensitive environments
- ✓ Payload: 7kg, arm span: 1008.5mm, maximum working radius: 886.5mm
- ✓ High performance, fast response, compact and lightweight

Applications

The AUBO iS series can be widely used across all industry scenarios, and is especially suitable for precision manufacturing, spraying, harsh/sensitive environments, and other special scenarios.



CERTIFICATIONS

- ISO 13849(PL d with Cat. 3)
- CE Certification
- NRTL Certification
- KCs Certification
- CR Certification
- SEMI S2 Certification
- RoHS Certification
- ISO class 4 Cleanroom ISO Class 4



Features & Advantages

- 01 Modular and easy to replace:** Adopts an integrated modular design with 6 standard module specifications, enabling quick replacement and more convenient maintenance.
- 02 Enhanced performance, high precision, and high speed:** Compared to the i series, repeatability, absolute accuracy, and trajectory accuracy are comprehensively improved, and the robotic arm moves faster.
- 03 Brand new design, stronger protection:** The payload-to-weight ratio reaches up to 1:3.2, with optimized core components and new control algorithms; fully enclosed structure with a maximum IP68 protection rating.
- 04 Lightweight, flexible, and widely applicable:** The new teach pendant weighs only 1kg, and the new control cabinet reduces footprint by 50%; all models come standard with a multi-functional tool end, expanding the application range.



High Performance



High Precision



Rapid Response



Safe and Stable



Flexible Production



Fine Craftsmanship



Compact and Lightweight



Modular Design



High Protection Class



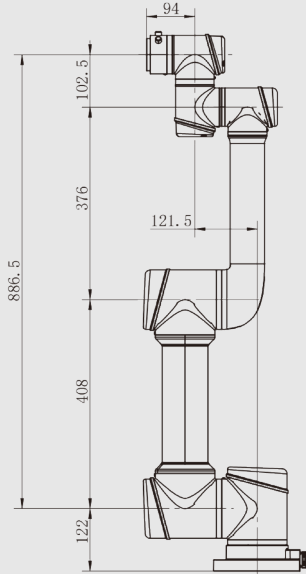

AUBO-iS7 Dimensions Diagram

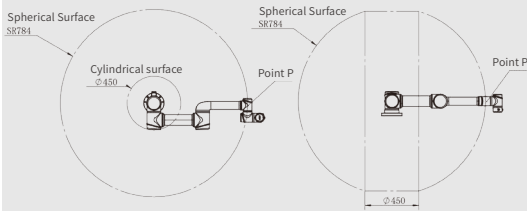

AUBO-iS7 Point P Motion Range

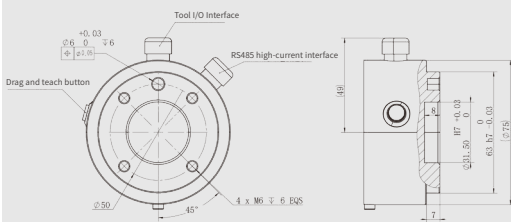

AUBO-iS7 End Flange

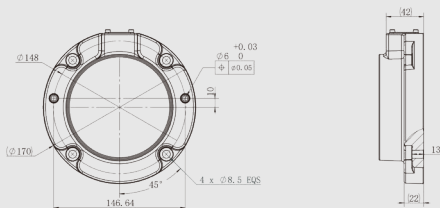

AUBO-iS7 Base Top View

Robot

Degrees of Freedom	6
Max Working Radius (mm)	886.5
Payload (kg)	7
Weight (kg)	21.5
Footprint Diameter (mm)	Ø170
Repeatability (mm)	±0.02
Tool Speed (m/s)	≤3.6
Average Power (W)	200
Peak Power (W)	2000
Operating Temp. Range (°C)	0-50
Operating Humidity	90% RH (Non-condensing)
Mounting	Any angle
IP Classification	IP67

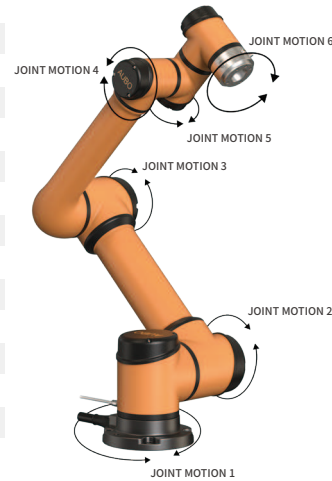

Joint Motion

Joint	Range of Motion(°)	Max Speed (°/s)
joint 1	±360	237
joint 2	±360	237
joint 3	±162	237
joint 4	±360	296
joint 5	±360	296
joint 6	±360	296

* Joint motion capabilities may be limited by application scenarios; maximum speeds may not be reached. Please note this during use.

Control Cabinet

Product Model	AUBO-CB-iS
Dimensions (L*H*W)	400mm*320mm*160mm
Weight	12.5kg
Robot Arm Cable Length	5m (Customizable, up to 8m)
Teach Pendant Cable Length	4m
Power Cable Length	5m
Communication Protocols	Ethernet, ModBus-RTU/TCP, Profinet, Ethernet/IP (Optional)
Interfaces & Openness	SDK (C/C++/C#/Lua/Python/JavaScript Windows + Linux)、supporting ROS/ROS2、AP
Power Supply	115/230VAC, 50/60Hz
IP Classification	IP43



I/O Interfaces

	Control Cabinet	Tool End
I/O Interfaces		
Digital Input	16(Standard),16(Configurable)/8(Safety)	4(Standard)
Digital Output	16(Standard),16(Configurable)/8(Safety)	4(Standard)
Analog Input	2	2
Analog Output	2	-
RS485 Communication	2	1
I/O Power		
Output Voltage	24V	0V/12V/24V
Output Current	3A Max	2A (3A Max)

Teach Pendant

Product Model	AUBO-TP-IS
Dimensions (L*H*W)	254mm*213.1mm*40.8mm
Weight	1.0kg
IP Classification	IP54
Color	Orange + Black



Disclaimer

- The content of this product datasheet is subject to change without prior notice.
- This product datasheet is the intellectual property of our company, and all rights are reserved. Any reproduction or citation of the content must indicate the source. Unauthorized reproduction is strictly prohibited; violators will be considered infringing and will be held legally liable in accordance with the law.

